

## DESCRIPTION

The UHF-R® is a professional, wireless technology engineered for the most demanding touring environments and installations.

UHF-R® wireless systems offer unprecedented flexibility and versatility. Using multiple frequency bands, up to 160 compatible systems can be used simultaneously. Individual frequency bands deliver up to 60 compatible systems per band. The UHF-R also includes infrared synchronization that allows you to configure transmitter settings from the receiver. With multiple system operation and interchangeable components, UHF-R systems also offer a choice of Single or Dual Channel Diversity Receivers.

## SYSTEM FEATURES

Shure UHF-R® Wireless Systems offer many exceptional features, including:

### Auto Frequency Selection/Scan

- Locates a clear channel instantly

### Auto Transmitter Sync

- Infrared (IR) sync automatically synchronizes the transmitter and receiver

### Networking

Each receiver has an RJ-45 port on the back that lets you connect to an Ethernet network. Networking receivers provides the following benefits:

- Makes channel setup faster and easier
- Allows you to monitor and control multiple receivers using the Shure Wireless Workbench PC Software

### Shure's Wireless Workbench Software

Key benefits of current Wireless Workbench software include:

- Fast network setup of large groups of wireless systems:
- Scans current RF environment.
- Plots RF history, using an individual transmitter to identify potential areas of weak signals and dropouts.
- Remote monitoring and control of multiple wireless systems.
- Wireless Workbench provides faster setup and more complete control.
- Automatic Frequency Selection Wizard: Will scan and select open frequencies, applying them to all Shure UHF-R receivers in network (and ultimately to connected networks of current UHF series receivers as well).
- Comprehensive Infra-Red (IR) Auto Sync/Automatic Transmitter Setup: PC control of transmitter sync with corresponding receiver. Syncs frequency, lockouts, power setting, custom groups.
- Frequency Compatibility Calculator Wizard: By scanning the RF environment and then considering all networked hardware models, Wireless Workbench recommends frequencies for all specified wireless systems (including PSM systems, and competitive product). While this feature has a proprietary slant, a generic hardware "template" will be available for those users who insist on networking with non-Shure products)
- The Band Limiting feature allows manufacturer or service center to set Network frequency band parameters, to align with any country/regional RF usage guidelines that might conflict with the available bandwidth.
- Custom Frequency Group Creation allows customization of frequency groups to be used in specific locations. May require advanced wireless aptitude, or assistance from Shure's Applications departments.

### Shure's patented Audio Reference Companding

- Delivers a crystal clear audio transmission, superior to conventional wireless technology

### UR4S & UR4D DIVERSITY RECEIVER FEATURES:

- Up to 2,400 selectable frequencies across up to 60 MHz bandwidth
- Track Tuning** Filtering Technology (on all 60 MHz or greater products).
- Up to 40 preset compatible systems/band (up to 160 with multiple bands).
- Network Automatic Frequency Selection
- Automatic Transmitter sync (**including custom Group Upload**)
- Flash memory to store six 60-channel custom frequency groups
- Shure's Patented Audio Reference Companding
- Multi-function bit-mapped backlit LCD
- Built-in **USB & Ethernet** network Control/Monitoring
- AMX/Crestron Compatible
- Remoteable 1/2 wave antenna
- Temperature-activated fan ensures top performance in high temperature environments. Clean fan screen as needed to remove dust.
- MARCAD® diversity

### HANDHELD AND BODYPACK TRANSMITTERS FEATURES

- Switchable RF Power (10/50 & 10/100 mW), country dependent
- Low profile, compact bodypack design
- Frequency and Power Lockout
- Bit-mapped Backlit LCD
- 2 AA Batteries - Up to 9.5 hours continuous use (low power)
- Automatic Transmitter Setup
- All-metal die-cast construction
- Light-weight magnesium bodypack
- Flexible bodypack antenna
- Reversible Belt Clip

## UHF-R™ Wireless System Specifications

### Frequency Range and Transmitter Output Power

Band	Range	Transmitter power (mW)	
		Handheld	Bodypack
<b>H4E, H4</b>	518-578 MHz	10 / 50 10 / 50	10 / 50 10 / 100
<b>J5E, J5</b>	578-638 MHz (578-608, 614-638)	10 / 50 10 / 50	10 / 50 10 / 100
<b>L3E, L3</b>	638-698 MHz	10 / 50 10 / 50	10 / 50 10 / 100
<b>Q5</b>	740-814 MHz	10 / 50	10 / 50
<b>R9</b>	790-865 MHz	10 / 50	10 / 50
<b>Q6</b>	740-752 MHz	10	10
<b>A24</b>	779-788 / 797-806 MHz	10	10
<b>JBX</b>	806-810 MHz	10	10
<b>Q10</b>	740-798 MHz	10 / 50	10 / 50
<b>G1</b>	470-530 MHz	10/50	10/100
<b>X1</b>	944-952 MHz	10/50	10/100

### NOTE

This Radio equipment is intended for use in musical professional entertainment and similar applications.

This Radio apparatus may be capable of operating on some frequencies not authorized in your region. Please contact your national authority to obtain information on authorized frequencies and RF power levels for wireless microphone products.

### RF Carrier Frequency Range

470-952 MHz, depending on region

### Working Range

UR1, UR2: 150 m (500 ft.), under typical conditions  
500 m (1600 ft) **line-of-sight, outdoors** for a single system

**NOTE:** Actual working range depends on RF signal absorption, reflection and interference

### Audio Frequency Response

40 – 18,000 Hz, (+1 dB, -3 dB).

**NOTE:** Overall system frequency response depends on microphone element

### Gain Adjustment Range

UR1: -20 to +35 dB  
UR2: -10 to +20 dB

### Modulation

FM (45 kHz max. deviation), compander system with pre- and de-emphasis

### RF Power Output

See table above.

### Dynamic Range

>105 dB, A-weighted

### Image Rejection

>110 dB typical

### RF Sensitivity

UR4S	UR4D
-110 dBm Typical 12 dB SINAD	-107 dBm Typical 12 dB SINAD
-105 dBm Typical 30 dB SINAD	-102 dBm Typical 30 dB SINAD

### Spurious Rejection

>90 dB typical

### Ultimate Quieting (ref. 45 kHz deviation)

>100 dB, A-weighted

### Signal Polarity

Positive pressure on microphone diaphragm (or positive voltage applied to tip of WA302 phone plug) produces positive voltage on XLR output pin 2 with respect to XLR pin 3 and on the tip of the 1/4-inch output jack.

### System Distortion (ref. ± 45 kHz deviation, 1 kHz modulation)

<0.3% Total Harmonic Distortion typical

### Power Requirements

UR1, UR2: Two 1.5V AA batteries  
UR4: 100 to 240 Vac, 50/60 Hz

### Current Drain

UR1, UR2: 180 mA max. (normal RF power setting)  
240 mA max. (high RF power setting)  
UR4D, UR4S: 0.8 Amps max.

### Battery Life (Typical)

UR1, UR2: 9.5 hours (low power)  
6 hours (high power)

### Operating Temperature Range

-18° to +57° C (0° to +135° F)

**NOTE:** Battery characteristics may limit this range

**NOTE:** Electrical safety approval is based on a maximum ambient temperature of 35°C (95°F).

### Overall Dimensions

UR1: 98 mm L x 60 mm W x 17 mm D (3.84 x 2.38 x 0.66 in.)  
UR2/SM58: 261 mm L x 51 mm Dia. (10.27 x 2 in.)  
UR2/SM86: 261 mm L x 51 mm Dia. (10.27 x 2 in.)  
UR2/SM87A: 254 mm x 51 mm Dia. (10 x 2 in.)  
UR2/BETA 58: 258 mm L x 51 mm Dia. (10.15 x 2 in.)  
UR2/BETA 87A,  
UR2/BETA 87C: 254 mm x 51 mm Dia. (10 x 2 in.)  
UR2/KSM9/BK,  
UR2/KSM9/SL: 250 mm x 49 mm Dia. (9 7/8 x 15/16 in.)  
UR4S/UR4D: 44 mm H x 483 mm W x 366 mm D (1.72 x 19.00 x 14.39 in.)

### Net Weight

UR1: 97 g (3.4 oz.) without battery  
UR2/SM58: 356 g (12.6 oz.) without battery  
UR2/BETA 58: 314 g (11.1 oz.) without battery  
UR2/SM86: 317 g (11.2 oz.) without battery  
UR2/SM87A: 298 g (10.5 oz.) without battery  
UR2/BETA 87A,  
UR2/BETA 87C: 325 g (11.5 oz.) without battery  
UR2/KSM9/BK,  
UR2/KSM9/SL: 410 g (14.4 oz.) without battery  
UR4S: 4.8 kg (10.6 lbs)  
UR4D: 5.0 kg (11.0 lbs)

### Housing:

UR1: Cast magnesium  
UR2: Aluminum die-cast handle and aluminum machined battery cup  
UR4S, UR4D: Galvanized steel

### Certification

UR1, UR2: Type Accepted under FCC Parts 74 (FCC ID: "DD4UR1" & "DD4UR1A" & "DD4UR2" & "DD4UR2A"). Certified by IC in Canada under RSS-123 and RSS-102 ("IC: 616A-UR1" and "IC: 616A-UR2"). Meets the essential requirements of the European R&TTE Directive 99/5/EC (ETSI EN 300-422 Parts 1 & 2, EN 301 489 Parts 1 & 9) and is eligible to carry the CE marking. **CE 0682 ①**

UR4S, UR4D: Authorized under the Declaration Of Conformity provision of FCC Part 15. Certified under Industry Canada to RSS-123 ("IC: 616A-UR4"). Meets the essential requirements of the European R&TTE Directive 99/5/EC (EN 301 489 Parts 1 & 9, EN 300 422 Parts 1 and 2). Eligible to carry the CE marking. **CE**

Conforms to Australian EMC requirements and is eligible for C-Tick marking. **① N108**

Have been granted the following Country Safety Approvals:

cULus Mark for US and Canada: Meets UL6500 and CSA/CAN E60065. UL GS-Certified to EN60065.

UR1, UR2: Type Accepted under FCC Parts 74 (FCC ID: "DD4UR1", "DD4UR1A", "DD4UR2", "DD4UR2A").

### Wiring

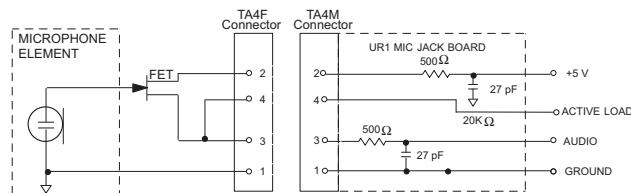

NOTE: LAVALIER MIC TIES PINS 3 AND 4 TOGETHER; GUITAR CABLE DOES NOT.

## INPUTS AND OUTPUTS

### UR1 Transmitter Audio Input

<b>Connector:</b>	4-Pin male mini connector (TA4M)
<b>Input Configuration:</b>	Unbalanced, active
<b>Actual Impedance:</b>	>1 MΩ
<b>Maximum Input Level:</b> 1 kHz, 1% THD	+10 dBu (sensitivity 0 dB) +20 dBu (sensitivity -10 dB)
<b>TA4M Connector Pin Assignments:</b>	Pin 1: Ground Pin 2: +5 Vdc bias Pin 3: Audio Pin 4: Tied through active load (on main board) to Ground. (On instrument adapter cable, Pin 4 floats)

### UR1 Transmitter RF Output

<b>Connector:</b>	SMA
<b>Actual Impedance:</b>	50 Ω
<b>Pin Assignments:</b>	Shell = Ground Center = Signal

### UR2 Transmitter Audio Input

<b>Input Configuration:</b>	Unbalanced, active
<b>Actual Impedance:</b>	>1 MΩ
<b>Maximum Input Level:</b> 1 kHz, 1% THD	+4.8 dBu

### UR2 Transmitter RF Output

<b>Connector:</b>	SMA
<b>Actual Impedance:</b>	50 Ω
<b>Pin Assignments:</b>	Shell = Ground Center = Signal

### Receiver Input

	Antenna	Power
<b>Connector Type:</b>	BNC	IEC
<b>Actual Impedance:</b>	50 Ω	-
<b>Nominal Input Level:</b>	-95 to -30 dBm	100-240 VAC, 50/60 Hz
<b>Maximum Input Level:</b>	-20 dBm	240 VAC, + 10%, 50/60 Hz
<b>Pin Assignments:</b>	Shell = Ground Center = Signal	IEC Standard
<b>Bias Voltage*</b>	12.2 Vdc @ 150 mA maximum	N/A

\* For remote antenna amplifiers

**Receiver Audio Output**

	Monitor (1/4" Headphone)	1/4" Phone	XLR
<b>Output Configuration:</b>	Unbalanced mono, 1/4 inch	Impedance Balanced	Electrically Balanced
<b>Actual Impedance:</b>	50 Ω	200 Ω	200 Ω (active balanced) (150 Ω mic)
<b>Maximum Output Level</b>	1 Watt @ 63 Ω	+18 dBu	+24 dBu (-6 dBu mic) with 100 Hz modulating tone
<b>Pin Assignments:</b>	Tip = Hot Ring = Hot Sleeve = Gnd	Tip = Hot Ring = no signal Sleeve = Gnd	1 = Ground 2 = Audio + 3 = Audio -
<b>Phantom Power Protection?</b>	No	Yes	Yes

**Computer/Network Interface**

<b>Ethernet</b>	<b>USB*</b>
RJ45	USB Series B Receptacle

\* USB-IF logo is a trademark of Universal Serial Bus Implementers Forum, Inc.

**XLR**

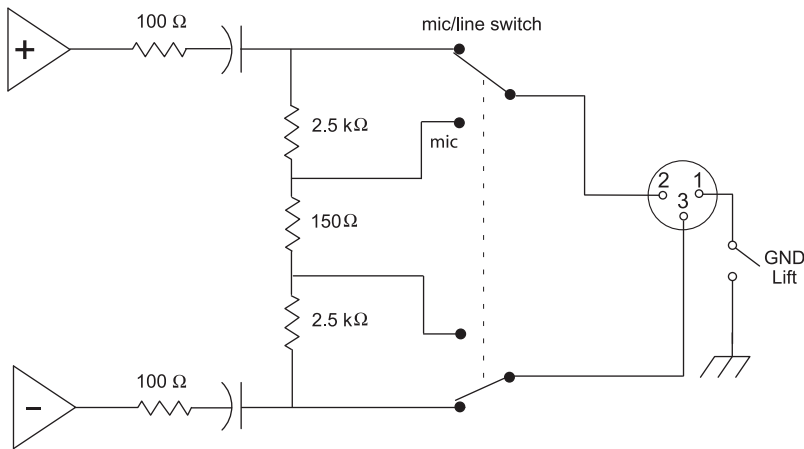

**1/4" Monitor/headphone**

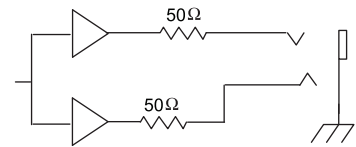

**1/4" Phone**

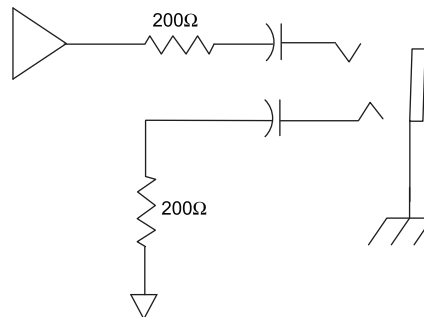

## REPLACEMENT PARTS AND ACCESSORIES

### Furnished Accessories

Microphone Stand Adapter (UR2)	WA371
Zipper Bag (UR1)	26A13
Zipper Bag (UR2)	26A14
Antenna Extension Cables (2)	95A9023
Hardware Kit, Locking Connector	WA340
Antenna (UR1), 470-530 MHz	UA700
Antenna (UR1), 944-952 MHz	UA740
Antenna (UR1), 518-578 MHz	UA710
Antenna (UR1), 578-698 MHz	UA720
Antenna (UR1), 740-865 MHz	UA730
Two Antennas (UR4), Band Dependent (see table)	UA820
Transmitter Carrying Case	95A9053

### Optional Accessories

SM58 Head with Grille	RPW112
SM86 Head with Grille	RPW114
BETA 58 Head with Grille	RPW118
BETA 87A Head with Grille	RPW120
BETA 87C Head with Grille	RPW122
SM87A Head with Grille	RPW116
KSM9/SL Head with Grille	RPW 180
KSM9/BK Head with Grille	RPW184
Matte Silver Grille (SM58)	RK143G
Matte Silver Grille (SM86)	RPM266
Matte Silver Grille (BETA 58)	RK265G
Black Grille (SM87)	RK214G
Matte Silver Grille (BETA 87A)	RK312
Matte Silver Grille (BETA 87C)	RK312
Black Grille (BETA 58)	RK323G
Black Grille (BETA 87A/BETA 87C)	RK324G
Belt Clip	44A8031
Body-Pack Pouch (Black), UR1	WA580B
Body-Pack Pouch (White), UR1	WA580W
Popper Stopper™ Windscreen	A85WS

### Antenna Combiners and Accessories

- Antennas and receivers must be from the same frequency band.
- The supplied 1/2 wave antennas can be remotely mounted or mounted directly to the UA845.
- Antennas and cables for use with the UA845 can also be used with stand-alone UHF-R receivers.

Passive Antenna/Splitter Combiner Kit (recommended for 2 receivers)	UA221
UHF Antenna Power Distribution Amplifier (recommended for 3 or more receivers)	UA845
U.S.A.	UA845SWB
Europe	UA845E
UK	UA845UK
1/2 Wave, Omnidirectional, Wideband Antenna	UA860SWB
Active Directional Wideband Antenna	UA870USTV and UA870X*
Wideband In-Line RF Amplifier	UA830USTV and UA830X*
Passive Unidirectional Wideband Antenna	PA805SWB
1/2 wave antennas (2)	
H4E, H4 Bands	UA820H4
J5E, J5 Bands	UA820J
L3E, L3 Bands	UA820L3
Q5, Q6, Q10 Bands	UA820Q
R9, ABJ, Bands	UA820A
G1 Band	UA820G
X1 Band	UA820X
25' Antenna Cable (RG-8/X)	UA825
50' Antenna Cable (RG-8/X)	UA850
100' Antenna Cable	UA8100

Note: USTV: 470-698 MHz. X: 944-952 MHz

### Architect's and Engineer's Specifications

The wireless system shall operate in the UHF band between 470 MHz and 952 MHz, with the specific range being dependent on the user's locale. The system shall include the option of changing the operating frequency in order to avoid RF interference, enabling up to 160 systems to operate simultaneously in the same location. Preconfigured group, channel and frequency setups shall be available to ensure that multiple systems in use do not interfere with one another.

All transmitters shall be powered by 2 AA batteries and shall have a power on/off switch. The bodypack will have an LED indicating that power is on. Available transmitters shall include: a body pack for use with electric guitars, basses, and other electric instruments, and a handheld microphone for vocals. The transmitters shall have a DC/DC converter to ensure consistent performance, even if battery voltages change.

The receiver shall have a user-programmable, menu-driven LCD showing group, channel, frequency, name, squelch level, and locked/unlocked status. The system shall use technology such as MARCAD® signal combining circuitry to improve reception, minimize signal dropouts, and achieve the best possible signal-to-noise ratio. An equalizer, tone key squelch, and noise squelch circuitry shall be built into the system to provide optimal sound quality and minimize unwanted noise. The receiver shall include dual RF meters (one for each antenna), an audio level meter, and a Networking Interface connector for computer control and monitoring. The receiver shall have a volume control and an adjustable noise squelch control.

The system shall be the Shure UHF-R Wireless.



**United States:**  
Shure Incorporated  
5800 West Touhy Avenue  
Niles, IL 60714-4608 USA

Phone: 847-600-2000  
Fax: 847-600-1212  
Email: info@shure.com

**Europe, Middle East, Africa:**  
Shure Europe GmbH  
Wannenäckestr. 28,  
74078 Heilbronn, Germany

Phone: 49-7131-72140  
Fax: 49-7131-721414  
Email: info@shure.de

**Asia, Pacific:**  
Shure Asia Limited  
Unit 301, 3rd Floor  
Citicorp Centre  
18, Whitfield Road  
Causeway Bay, Hong Kong

Phone: 852-2893-4290  
Fax: 852-2893-4055  
Email: info@shure.com.hk

**Canada, Latin America, Caribbean:**  
Shure Incorporated  
5800 West Touhy Avenue  
Niles, IL 60714-4608 USA

Phone: 847-600-2000  
Fax: 847-600-6446  
Email: international@shure.com